

2601/104

2602/104

2603/104

ENGINEERING DRAWING,  
MATERIALS, PROCESSES AND  
WORKSHOP TECHNOLOGY

June/July 2017

Time: 3 hours

Scanned

easyvet.com



THE KENYA NATIONAL EXAMINATIONS COUNCIL

DIPLOMA IN ELECTRICAL AND ELECTRONIC ENGINEERING  
(POWER OPTION)  
(TELECOMMUNICATION OPTION)  
(INSTRUMENTATION OPTION)  
MODULE I

ENGINEERING DRAWING, MATERIALS, PROCESSES AND WORKSHOP TECHNOLOGY

3 hours

INSTRUCTIONS TO CANDIDATES

*You should have the following for this examination.*

*Mathematical table/Non-programmable scientific calculator;*

*Drawing instruments*

*Drawing paper (size A3).*

*The paper consists of EIGHT questions in TWO sections; A and B.*

*Answer any THREE questions from section A and any TWO questions from section B in the answer booklet and drawing papers provided.*

*All questions carry equal marks.*

*Maximum marks for each part of the question are as indicated.*

*Candidates should answer all questions in English.*

**This paper consists of 7 printed pages.**

**Candidates should check the question paper to ascertain that all the pages are printed as indicated and that no questions are missing.**

## SECTION A

Answer any **THREE** questions from this section.

1. (a) (i) Outline the procedure for extinguishing flames that have engulfed a person.  
(ii) List **three** contents of a first aid kit. (8 marks)
- (b) Describe the following metal finishes and decorative processes:  
(i) pickling;  
(ii) annealing. (4 marks)
- (c) Explain the following metal forming processes:  
(i) forging;  
(ii) foundry work. (4 marks)
- (d) Draw a vernier scale to show a reading of 10.02 cm. (4 marks)
2. (a) List **three**:  
(i) marking out tools; *scribing*  
(ii) cutting tools. (6 marks)
- (b) (i) Draw a labelled diagram of a flat file.  
(ii) State **four** precautions in handling and storage of files. (8 marks)
- (c) Explain the following methods of joining metals:  
(i) riveting;  
(ii) bolting. (6 marks)

3. (a) Explain the following drilling machine operations:

- (i) Reaming;
- (ii) boring.

(4 marks)

(b) Illustrate the following lathe machine left cutting tools:

- (i) Facing;
- (ii) Roughing;
- (iii) Finishing.

(6 marks)

(c) Figure 1 shows a bench grinding machine. Name the parts labelled A - F. (6 marks)

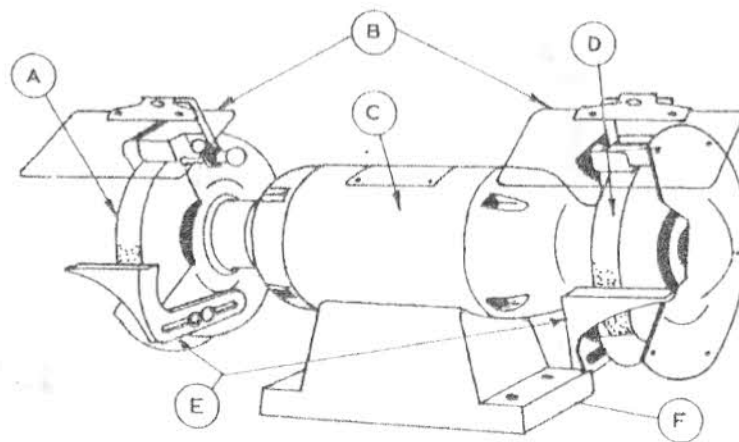

Fig. 1

(d) State the safety precautions when using the grinding machine. (4 marks)

(4 marks)

4. (a) State:

- (i) **two** properties of aluminium.
- (ii) **three** classifications of electrical materials.

(5 marks)

(b) (i) Explain the term 'corrosion'.

(ii) List **three** factors that determine the corrosion of metals.

(5 marks)

(c) With the aid of a labelled diagram, describe the extraction of iron from the ore. (10 marks)

(10 marks)

## SECTION B

Answer any **TWO** questions from this section.

5. (a) Figure 2 shows a circular wheel of 40 mm diameter with point P attached to its periphery. The wheel rolls without slipping along a straight line while remaining on the same plane. Plot the path of point P for a full revolution of the wheel.

(10 marks)

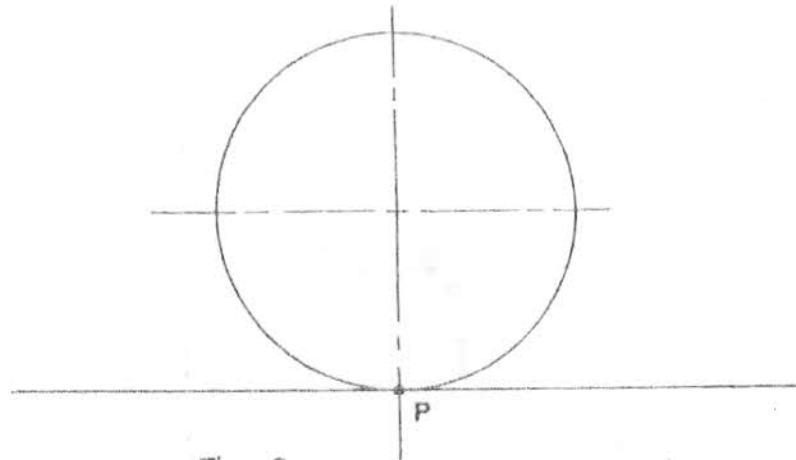

Fig. 2

- (b) Inscribe **two** circles of radii 20 mm and 15 mm within a third circle of diameter 80 mm and all the three circles to touch each other. (5 marks)
- (c) Construct a regular pentagon given the length of one side as 50 mm, using the compass method. (5 marks)

6. Figure 3 shows a pictorial view of a bracket. Draw full size in first angle projection the following views:

- (a) Sectional front elevation A-A;
- (b) An end elevation in the direction of arrow E;
- (c) A sectional plan on B-B.

Include six major dimensions.

(20 marks)

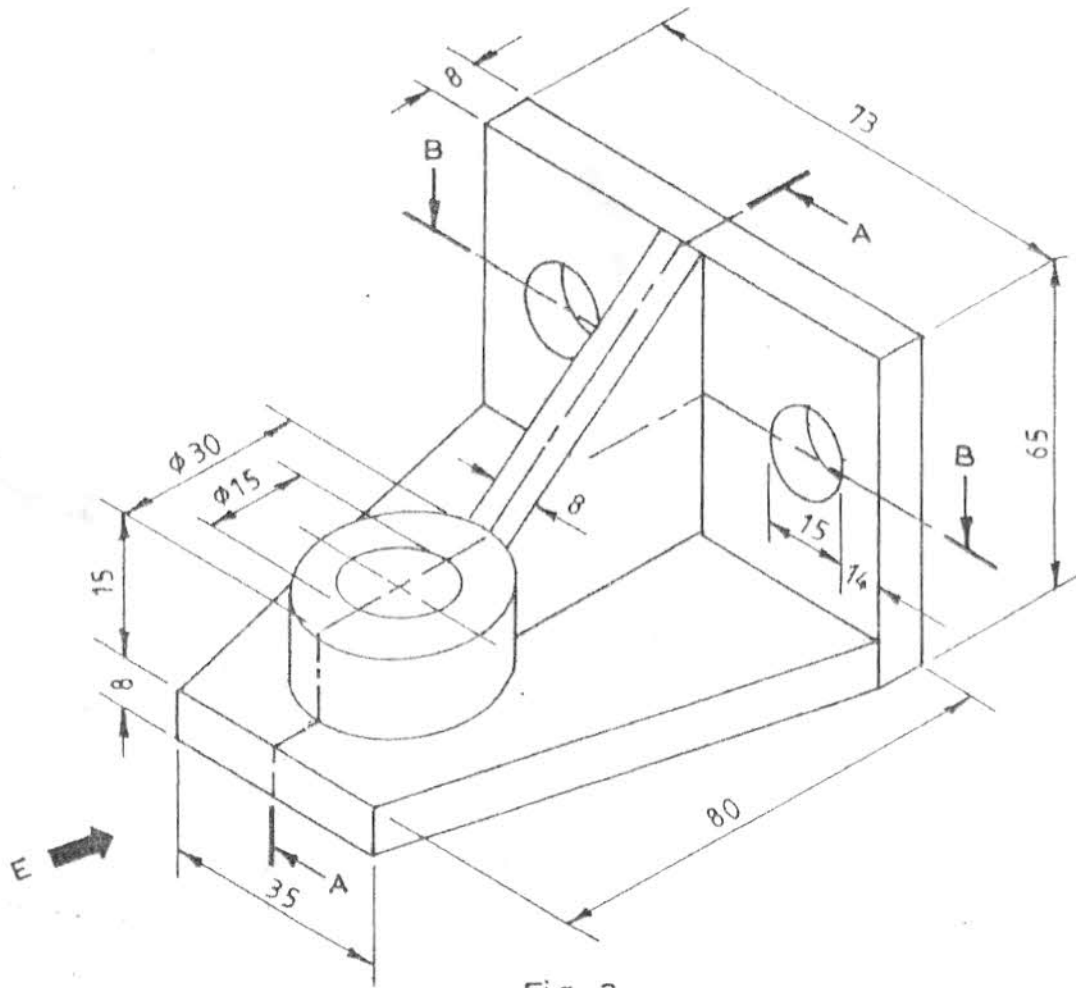

Fig. 3

7. Figure 4 shows the front elevation of a truncated cylinder. Copy the given view and draw the:

- (a) plan;
- (b) true shape at cutting plane X-X;
- (c) surface development of the cylinder.

(20 marks)

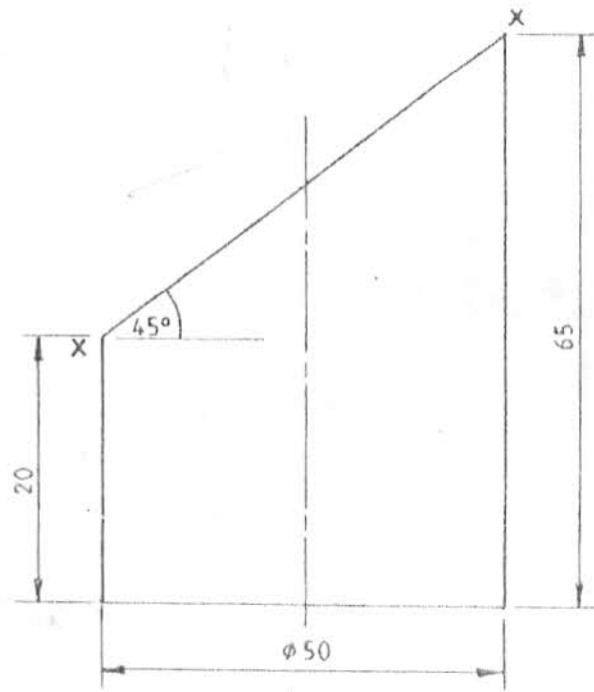

Fig. 4

8. Figure 5 shows two views of a bracket drawn in third angle projection. Draw full size the bracket in isometric projection taking corner X as the lowest point.

(20 marks)

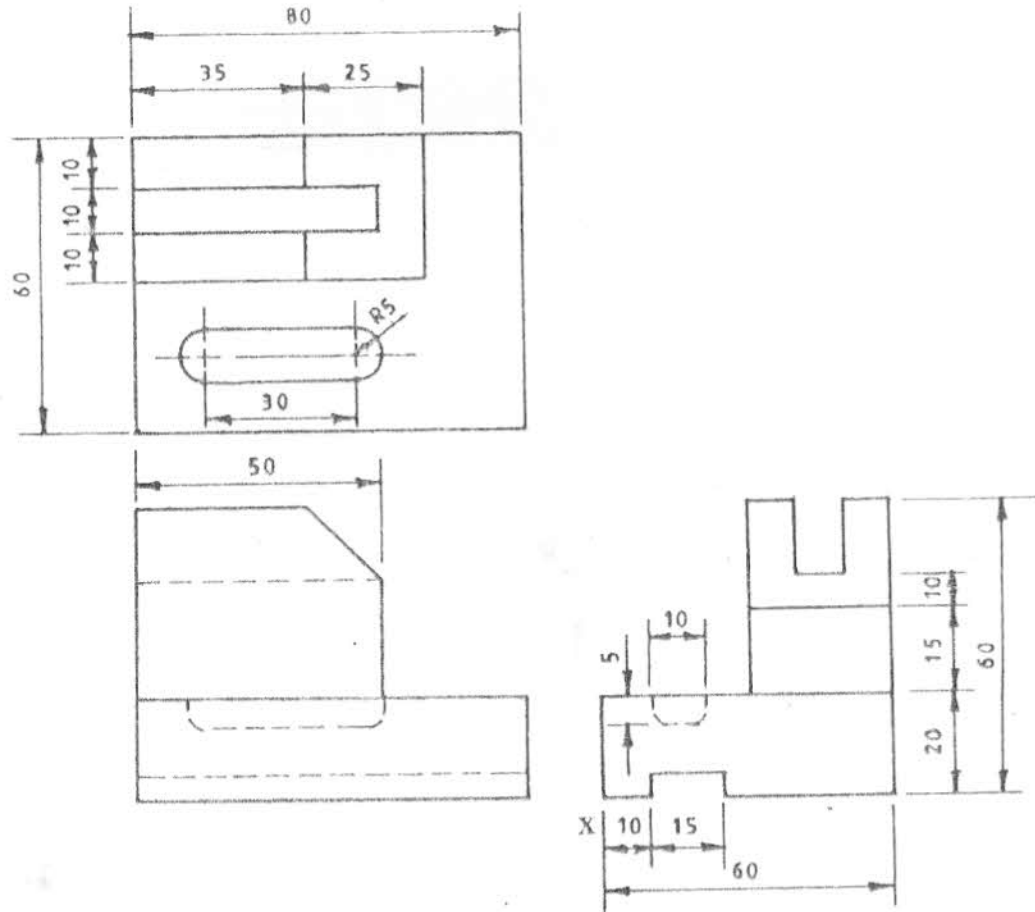

Fig. 5

THIS IS THE LAST PRINTED PAGE.